

# BILL of MATERIALS

Qty.	PART #	DESCRIPTION
1	LW-702	50 QT. COOLER W/ FOAM
2	000261	33.5" X 2" X 0.312" ALUM. BAR
2	000271	2 1/2" 3" S.S. BUTT HINGE
1	090801-00	COOLER PLUG
60.00*	099202	COOLER GASKET FOAM
4	124012	#12 X 1-1/4 PH PN SS SCREW
4	304211	1/4-20 X 1/2" PH PN SS SCREW
6	304216	1/4-20 X 3/4" PH OV SS SCREW
2	305569-1	5/16 X 4" MOELLER HANDLE (GRAY)
1	PF1005-3	SM. INJECTION F/F SEAT BACK W/ RIM FOAM & UPH.
1	PF1005-4	SM. INJECTION F/F SEAT BTM W/ RIM FOAM & UPH.
2	ST1444	ROTO-MOLDED REMOVABLE MOUNTS

NOTE: BACK & BOTTOM ILLUSTRATIONS  
DO NOT INCLUDE RIM FOAM OR UPHOLSTERY.

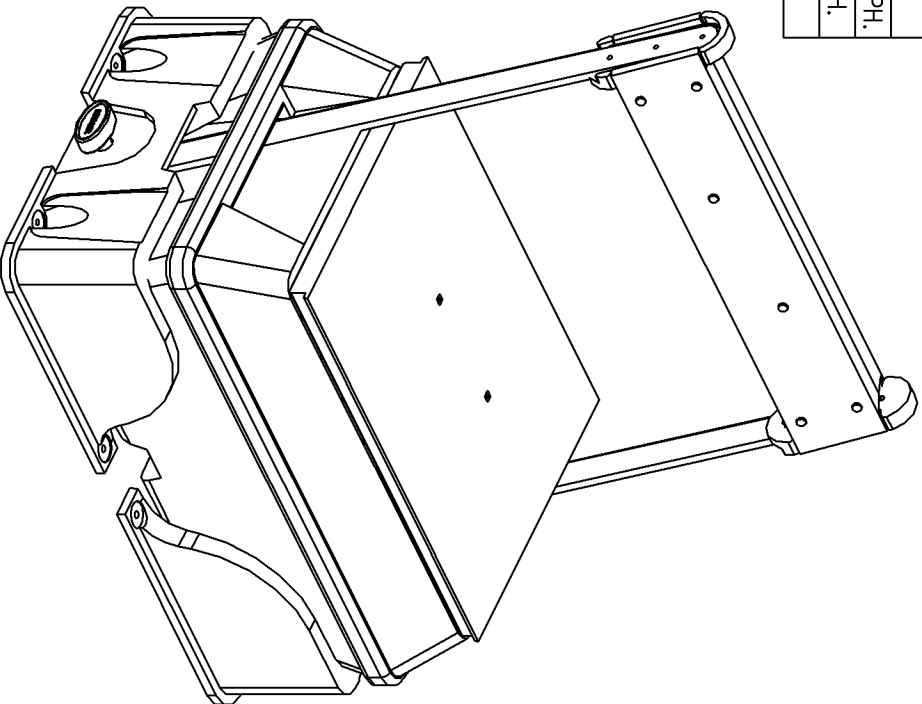

NO.	REVISION	DATE
1	REPLACE 099801 WITH 090801-00	7/11/02
2	REPLACE ROTO BACK & BOTTOM W/ INJECTION.	5/11/05

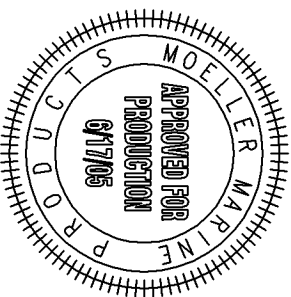

THIS DRAWING AND THE ATTACHED DRAWINGS (AND THE DATA SHOWN THEREON) IS CONFIDENTIAL AND PROPRIETARY AND SHALL NOT BE USED, DISCLOSED TO OTHERS, REPRODUCED FOR ANY PURPOSE EXCEPT FOR QUOTATION TO OR ORDER BY MOELLER MARINE PRODUCTS, INC. AND/OR ITS SUBSIDIARIES WITHOUT THEIR WRITTEN CONSENT TO THE USE OF SUCH DRAWINGS AND/OR DATA.

DESCRIPTION	SMALL DELUXE F/F COOLER, INJECTION BACK & BTM W/ RIM FOAM & UPHOLSTERY - ASSEMBLY
PART #	ST2800
MATERIAL	COLOR WHITE
TOLERANCES	±1.5% UNLESS OTHERWISE NOTED
WALL THK.	DATE 6/17/05
DRAWN BY	MOELLER ENGINEERING