

# BILL of MATERIALS

NO.	REVISION	DATE
1	REPLACE ALUMINUM FILL W/ MOLDED	6/27/09

Qty.	DESCRIPTION
1	PRIME SENDING UNIT 13.10"
1	ALUM. PL3 PICKUP W/O BARB
1	3/8 NPT INSERT W/ 5/8" BARB (VENT)
1	Ø1.50 X 2.75 MOLDED FILL
	OVERALL HEIGHT 17.25"

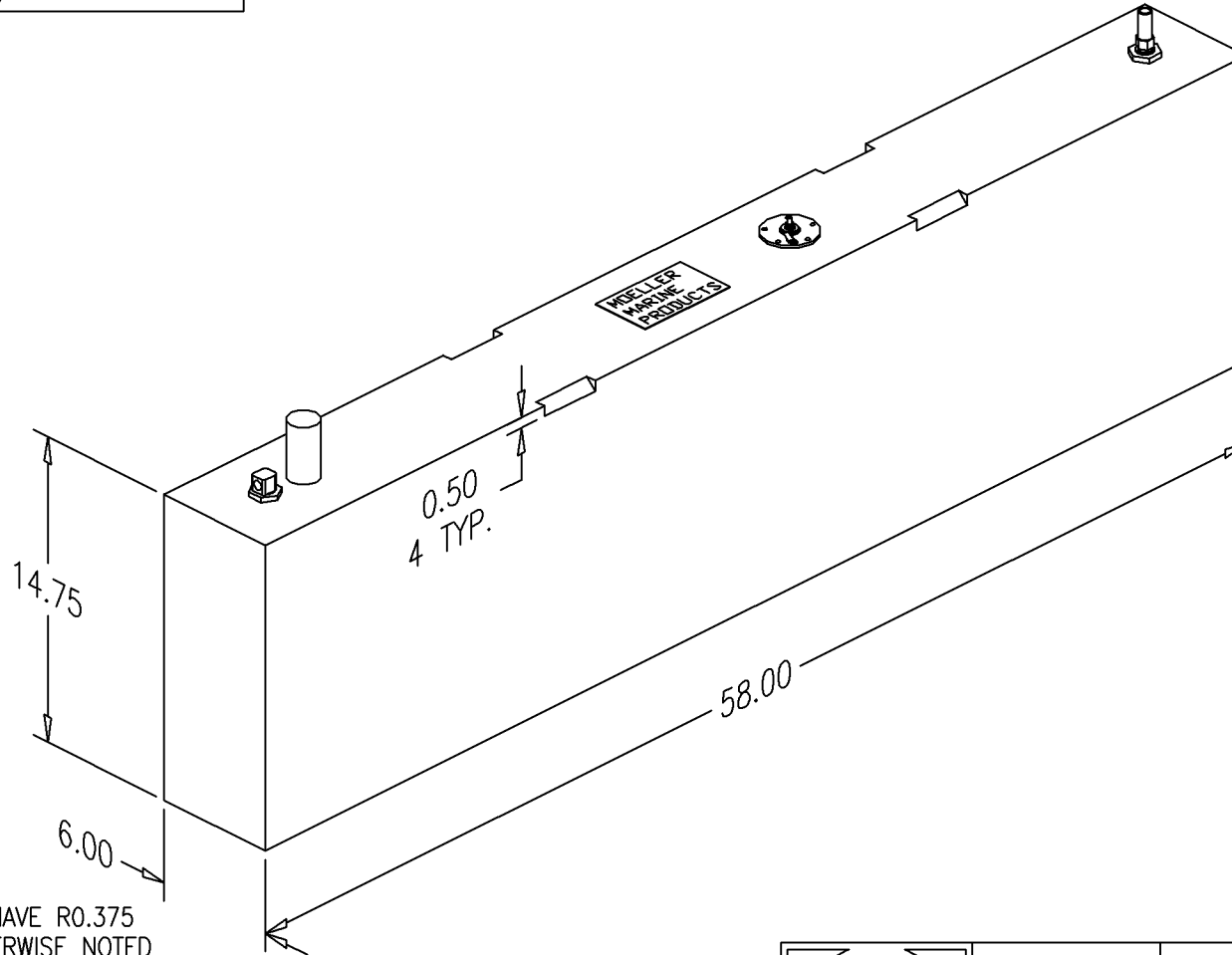

NOTE: ALL EDGES HAVE R0.375  
UNLESS OTHERWISE NOTED

PAGE 1 OF 2

THIS DRAWING AND THE ATTACHED DRAWINGS (AND THE DATA SHOWN THERON) IS CONFIDENTIAL AND PROPRIETARY AND SHALL NOT BE USED, DISCLOSED TO OTHERS, REPRODUCED FOR ANY PURPOSE EXCEPT FOR QUOTATION TO OR ORDER BY MOELLER MARINE PRODUCTS, INC. AND/OR IT'S SUBSIDIARIES WITHOUT THEIR WRITTEN CONSENT TO THE USE OF SUCH DRAWINGS AND/OR DATA.

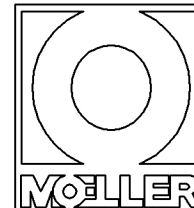

DESCRIPTION	20 GALLON FUEL TANK (032818)		
PART #	FT2098-1	COLOR	NATURAL
MATERIAL	CROSSLINK POLYETHYLENE		
TOLERANCES	±1.5% UNLESS OTHERWISE NOTED		
WALL THK.	0.200"	DATE	6/27/09
DRAWN BY	MOELLER ENGINEERING		

