

# BILL of MATERIALS

Qty.	DESCRIPTION
1	ROCHESTER SENDING UNIT 11.60"
1	ALUM. PL3 PICKUP W/O BARB
1	3/8 NPT INSERT W/ 5/8" BARB (VENT)
1	Ø1.50 X 2.75 MOLDED FILL
	OVERALL HEIGHT 14.25"

NO.	REVISION	DATE
1	REPLACE ALUMINUM FILL W/ MOLDED	6/27/09
2	REPLACE PRIME W/ ROCHESTER	9/10/09

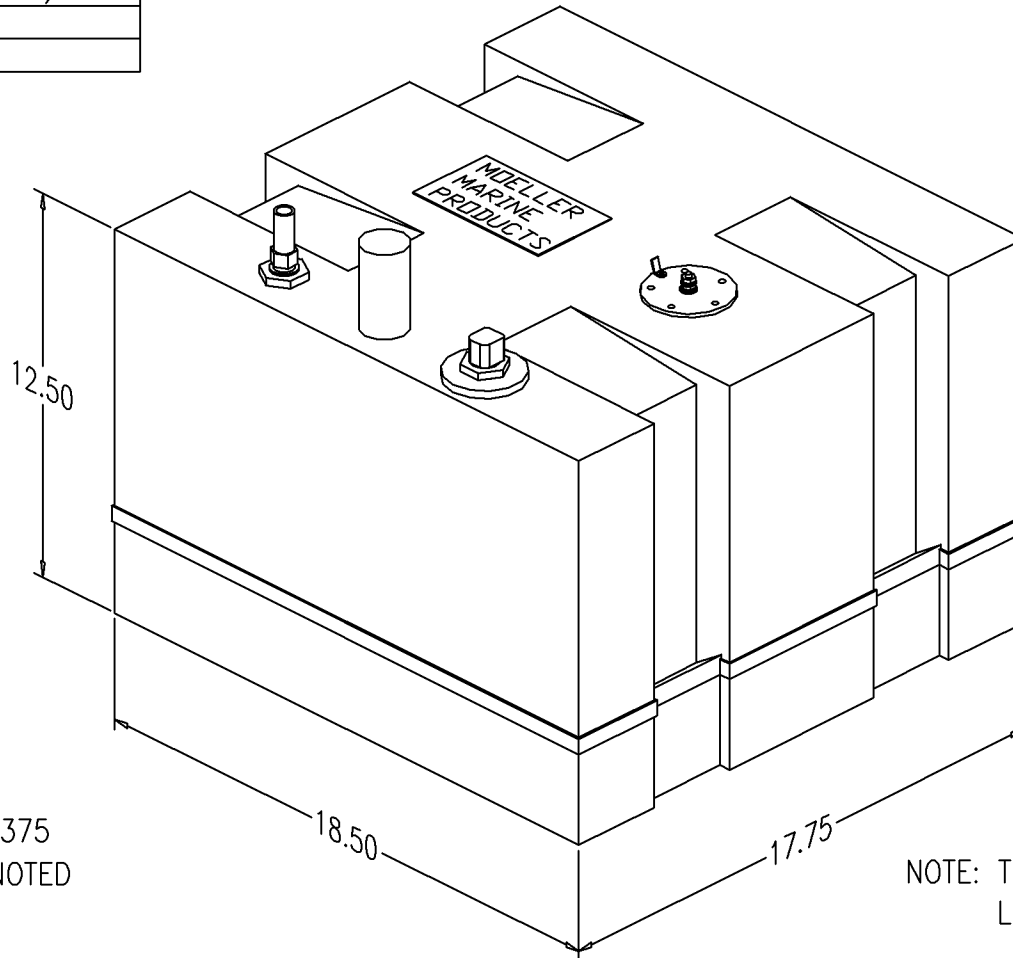

NOTE: ALL EDGES HAVE R0.375  
UNLESS OTHERWISE NOTED

NOTE: THIS IS AN ADDITIONAL  
LID TO WORK W/FT1515 BOTTOM

PAGE 1 OF 3

© 2007 MOELLER MARINE PRODUCTS  
ALL RIGHT RESERVED

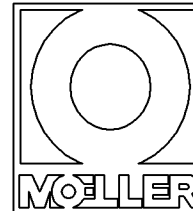

DESCRIPTION	15 GALLON FUEL TANK (032515)		
PART #	FT1599-1	COLOR	NATURAL
MATERIAL	CROSSLINK POLYETHYLENE		
TOLERANCES	±1.5% UNLESS OTHERWISE NOTED		
WALL THK.	0.200"	DATE	9/10/09
DRAWN BY	MOELLER ENGINEERING		

THIS DRAWING AND THE ATTACHED DRAWINGS (AND THE DATA SHOWN THERON) IS CONFIDENTIAL AND PROPRIETARY AND SHALL NOT BE USED, DISCLOSED TO OTHERS, REPRODUCED FOR ANY PURPOSE EXCEPT FOR QUOTATION TO OR ORDER BY MOELLER MARINE PRODUCTS, INC. AND/OR IT'S SUBSIDIARIES WITHOUT THEIR WRITTEN CONSENT TO THE USE OF SUCH DRAWINGS AND/OR DATA.



