

FUEL TANK INSTALLATION MUST ALLOW 3% GROWTH IN ALL DIRECTIONS. ANY DESIGNS NOT COMPLIANT WITH ABYC STANDARDS OR ARE CONSIDERED "GREY AREA" UNDER THESE STANDARDS WILL BE NOTED HERE IN. THIS PRINT AND ANY ATTACHED ARE PREPARED FOR CUSTOMER APPROVAL, PERFORMING THIS ACTION RELIEVES MOELLER MARINE PRODUCTS OF LIABILITY ASSOCIATED WITH TANK DESIGN.

NO.	REVISION	DATE	DRAFTER
1	-		

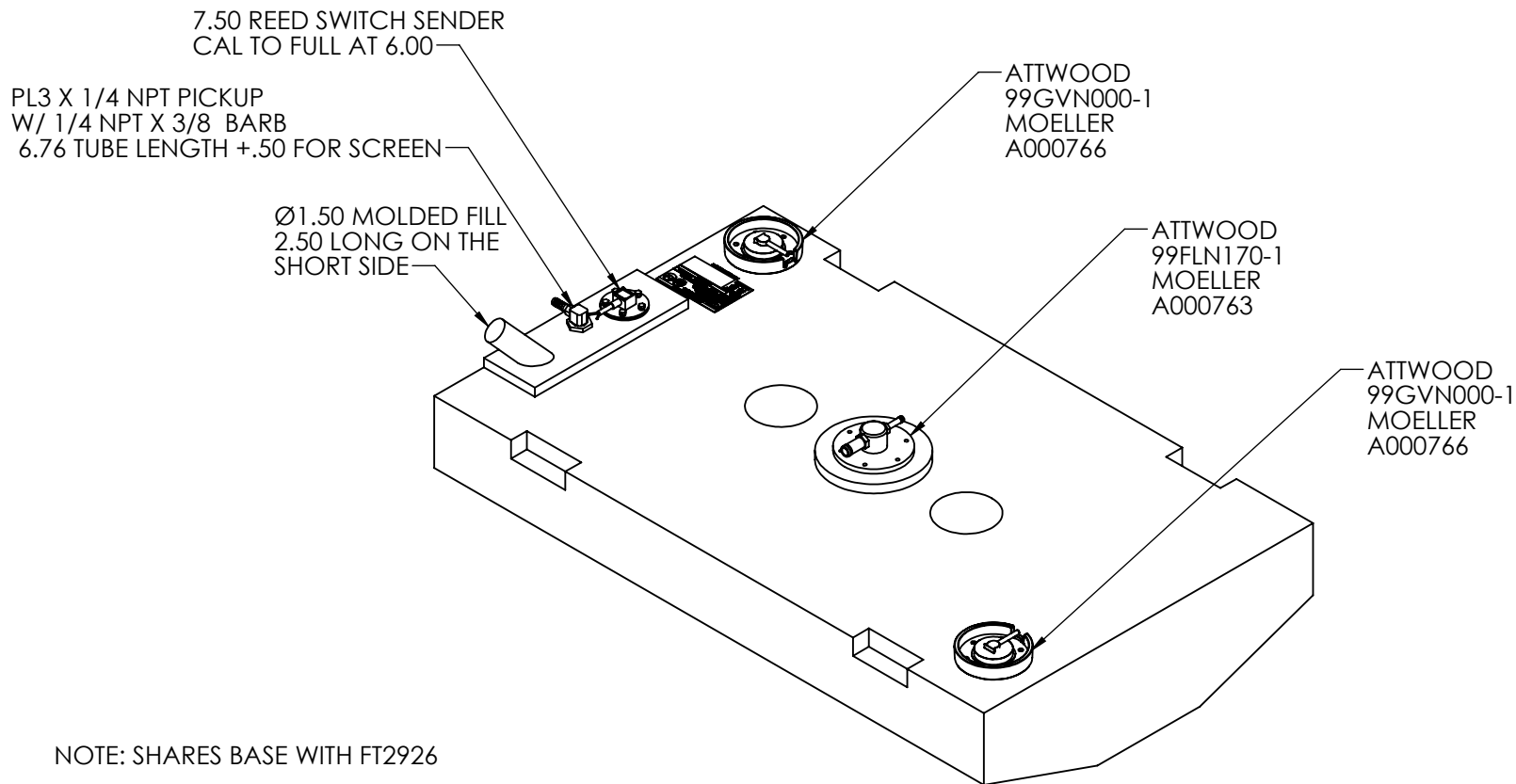

NOTE: SHARES BASE WITH FT2926

ZIPTIE BRACKETS
TO TOP OF TANK.

PAGE 1 OF 3

© 2012 MOELLER MARINE PRODUCTS
ALL RIGHT RESERVED

NOTE: ALL EDGES R0.38
UNLESS OTHERWISE NOTED
330 SHOT BLAST SURFACE TEXTURE
1° DRAFT ON ALL EXTERIOR SURFACES AS NEEDED

THIS DRAWING AND THE ATTACHED DRAWINGS (AND THE DATA SHOWN THERON) IS CONFIDENTIAL AND PROPRIETARY AND SHALL NOT BE USED, DISCLOSED TO OTHERS, REPRODUCED FOR ANY PURPOSE EXCEPT FOR QUOTATION TO OR ORDER BY MOELLER MARINE PRODUCTS, INC. AND/OR IT'S SUBSIDIARIES WITHOUT THEIR WRITTEN CONSENT TO THE USE OF SUCH DRAWINGS AND/OR DATA.

CUSTOMER PART # TBD
EPA CERTIFIED

CUSTOMER APPROVAL	
NAME:	<i>cory nash</i>
DATE:	11-20-12

	DESCRIPTION	≤29 GALLON FUEL TANK (110 L)		
	PART #	FTA001109BR	COLOR	NATURAL
	MATERIAL	CROSSLINK POLYETHYLENE W/BARRIER		
	TOLERANCES	±1.5 % UNLESS OTHERWISE NOTED		
	WALL THK.	0.200" NOMINAL	DATE	11/16/12
DRAWN BY	AMC			

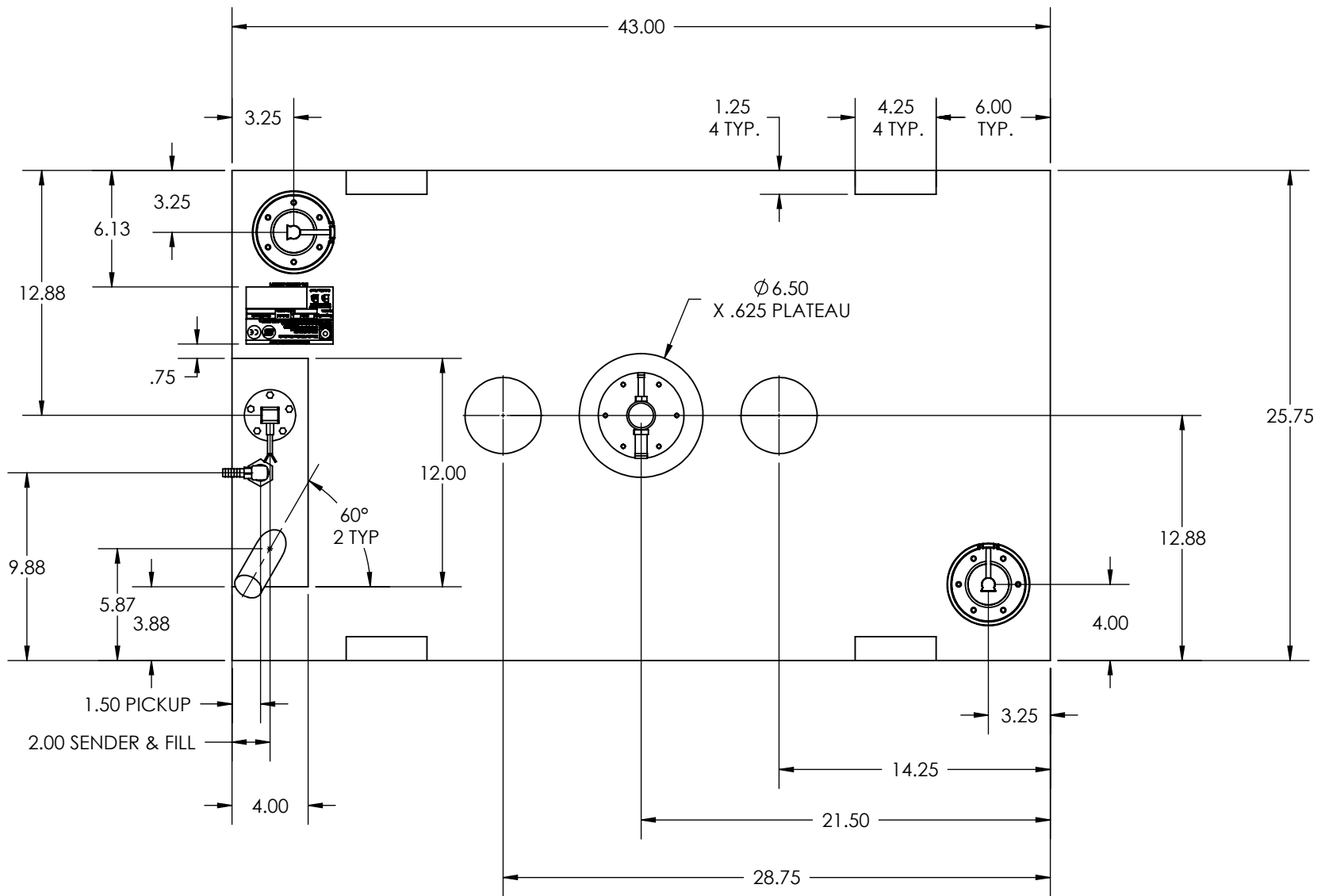

NOTE: CONES ARE Ø4.00 AT TOP OF TANK
 Ø5.00 AT BOTTOM OF TANK.

FILL IS ANGLED 45° FROM VERTICAL

