

BILL of MATERIALS

Qty.	DESCRIPTION
4	1/4--20 SS T-NUTS
	OVERALL HEIGHT 17.00"

NO.	REVISION	DATE
1	ADD 1 T-NUTS	10/31/97
2	CHANGE COLOR TO DRY WHITE	5/28/98
3	REVISE ARMS ON SEAT	10/14/99
4	REVISE KISSOFF, ADD 0.50" MOLDED THRU HOLE	11/9/99

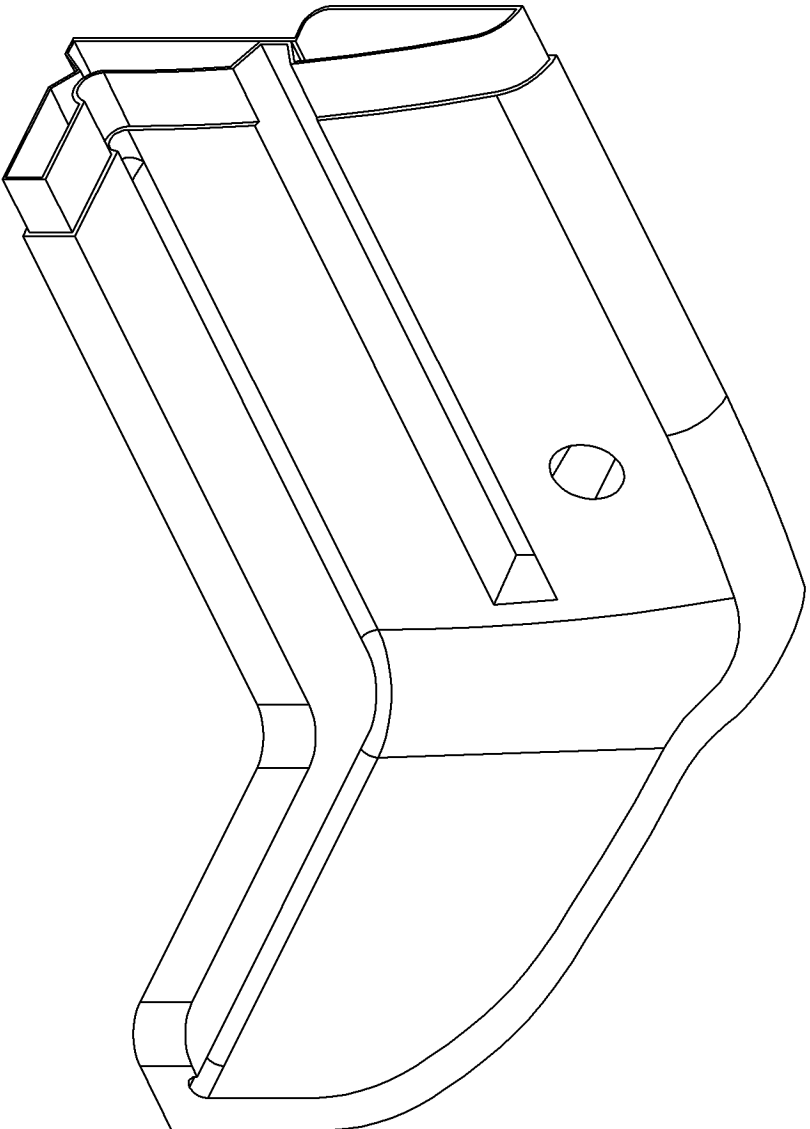

OVERALL SEAT DIMENSION	
HEIGHT	17.00
WIDTH	30.50
DEPTH	22.50
INTERNAL SEAT DIMENSION	
HEIGHT	15.00
WIDTH	27.50
DEPTH	19.00

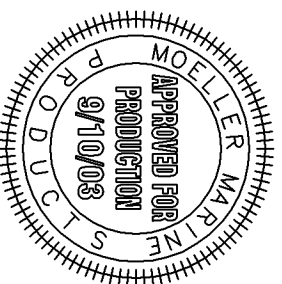

NOTE: ALL EDGES RO.38
UNLESS OTHERWISE NOTED

PAGE 1 OF 5

THIS DRAWING AND THE ATTACHED DRAWINGS (AND THE DATA SHOWN THEREON) IS CONFIDENTIAL AND PROPRIETARY AND SHALL NOT BE USED, DISCLOSED TO OTHERS, REPRODUCED FOR ANY PURPOSE EXCEPT FOR QUOTATION TO OR ORDER BY MOELLER MARINE PRODUCTS, INC. AND/OR ITS SUBSIDIARIES WITHOUT THEIR WRITTEN CONSENT TO THE USE OF SUCH DRAWINGS AND/OR DATA.

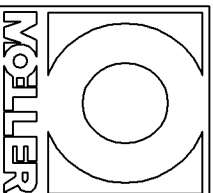

DESCRIPTION	STERN SEAT PORT SIDE	
PART #	ST1171	COLOR WHITE
MATERIAL	LINEAR POLYETHYLENE	
TOLERANCES	±1.5% UNLESS OTHERWISE NOTED	
WALL THK.	0.150"	DATE 11/9/99
DRAWN BY	MOELLER ENGINEERING	

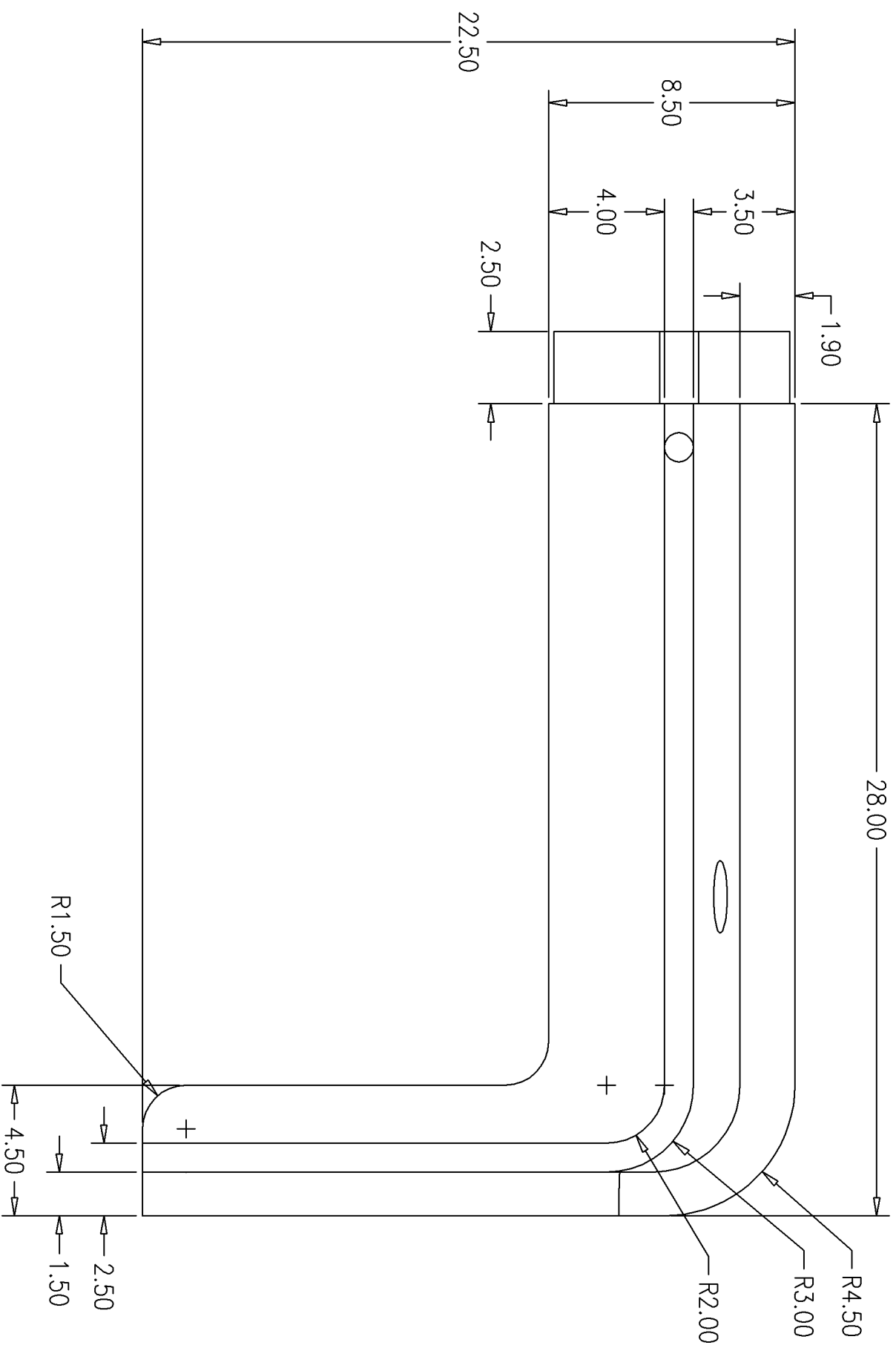

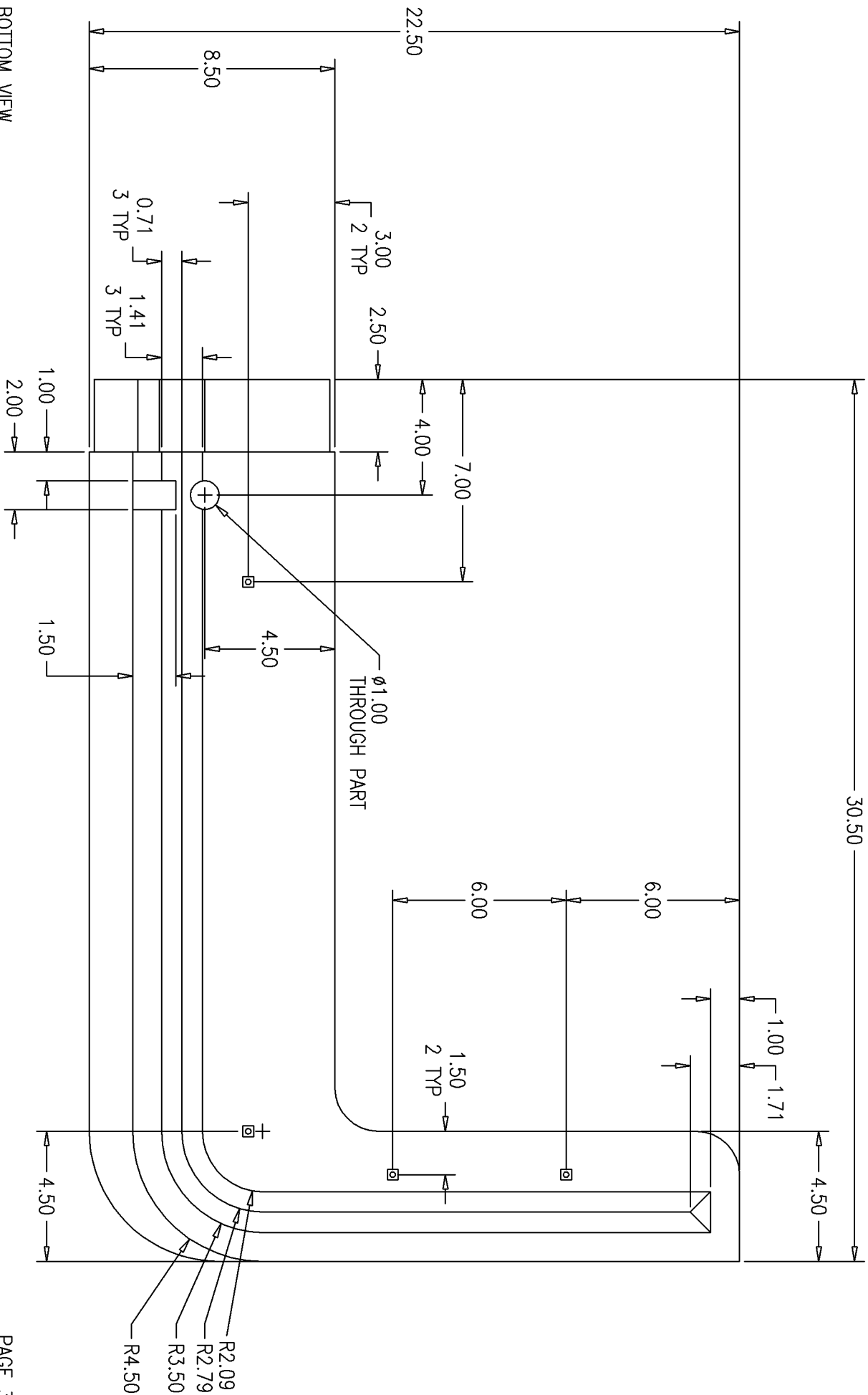

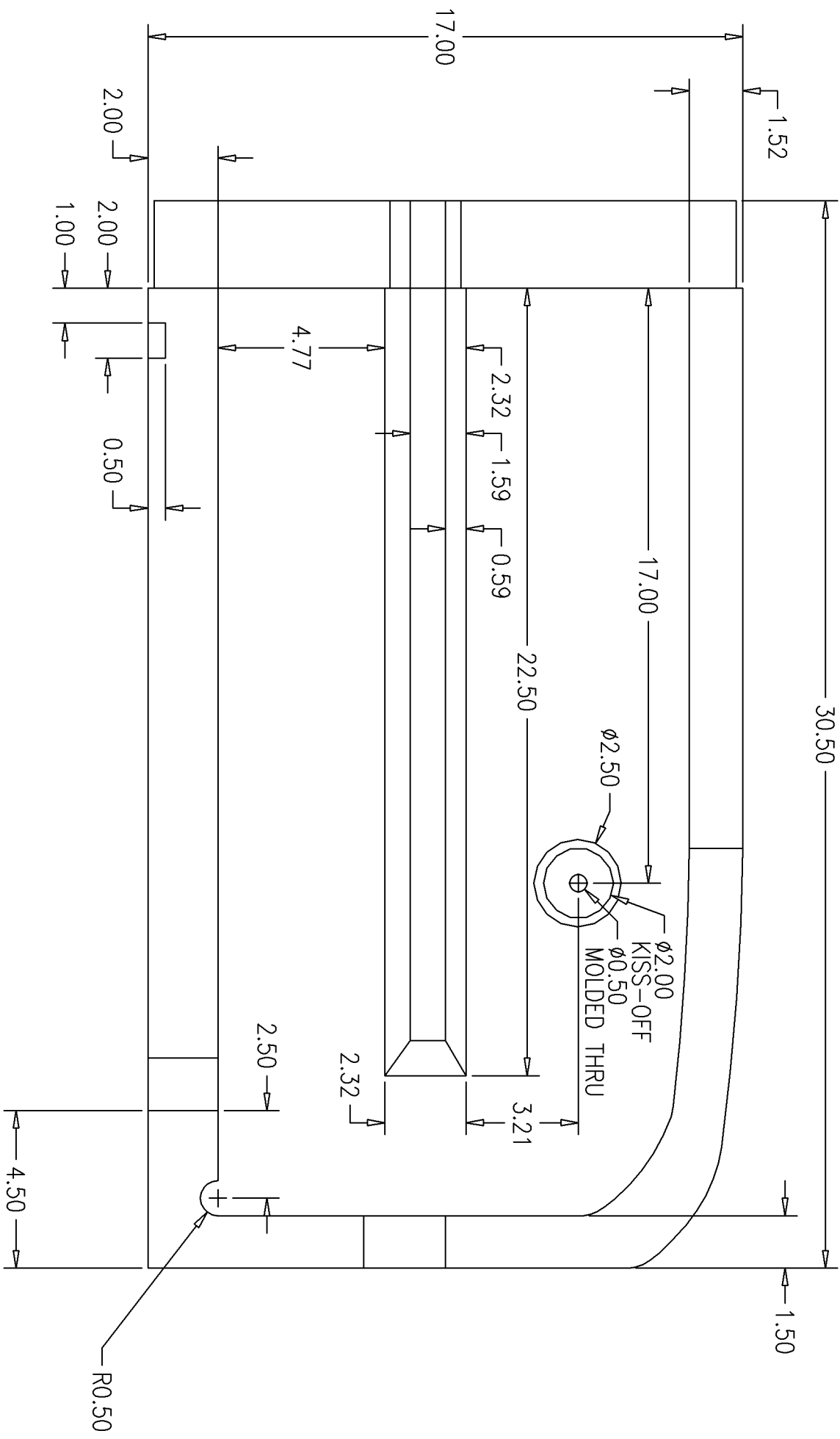

FRONT VIEW
11/9/99