

BILL of MATERIALS

Qty.	DESCRIPTION
1	PRIME SENDING UNIT 15.35"
1	ALUM. PL3 PICKUP W/O BARB
2	HOOK POCKETS W/O BRACKETS
2	3/8 NPT INSERTS W/ 5/8 BARBS (VENTS)
1	Ø1.50 ALUM. FILL W/ GROUND TAG
	OVERALL HEIGHT 19.25"

NO. _____ REVISION _____ DATE _____

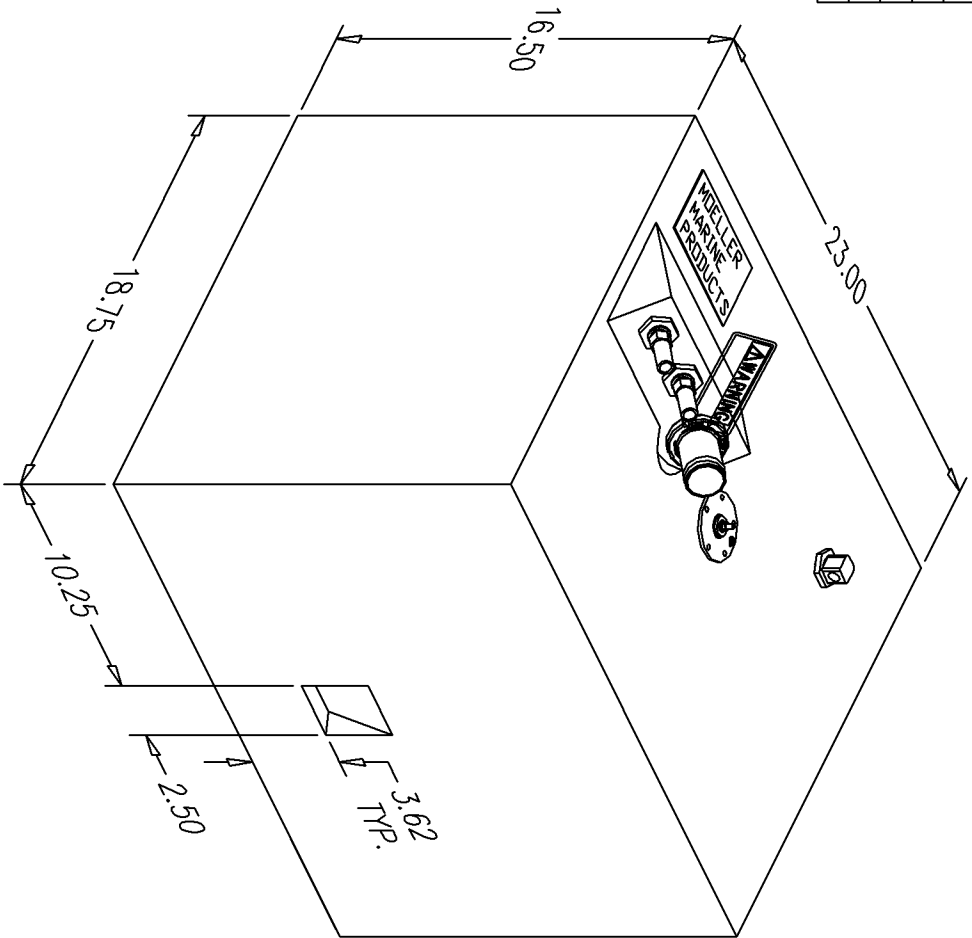

NOTE: ALL EDGES HAVE R0.375
UNLESS OTHERWISE NOTED

PAGE 1 OF 3

THIS DRAWING AND THE ATTACHED DRAWINGS (AND THE DATA SHOWN THEREON) IS CONFIDENTIAL AND PROPRIETARY AND SHALL NOT BE USED, DISCLOSED TO OTHERS, REPRODUCED FOR ANY PURPOSE EXCEPT FOR QUOTATION TO OR ORDER BY MOELLER MARINE PRODUCTS, INC. AND/OR ITS SUBSIDIARIES WITHOUT THEIR WRITTEN CONSENT TO THE USE OF SUCH DRAWINGS AND/OR DATA.

		DESCRIPTION	29 GALLON FUEL TANK (032629)
		PART #	FT2913-1
MATERIAL	CROSSLINK POLYETHYLENE	COLOR	NATURAL
TOLERANCES	±1.5% UNLESS OTHERWISE NOTED	DATE	9/13/06
WALL THK.	0.200"	DRAWN BY	MOELLER ENGINEERING

