

BILL of MATERIALS

Qty.	DESCRIPTION
1	ROCHESTER SENDING UNIT, DBL PLATED
1	ALUM. PL3 PICKUP W/O BARB
1	3/8 NPT INSERT W/ 5/8" BARB (VENT)
1	Ø1.50" ALUM. FILL W/ GROUND TAG
	OVERALL HEIGHT 18.75"

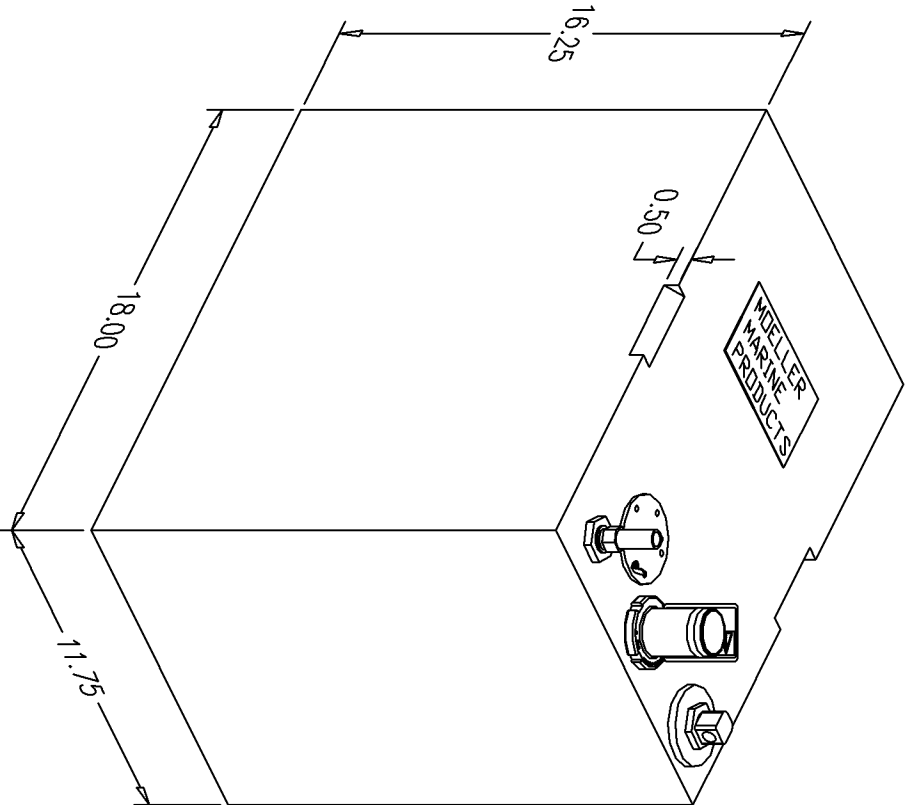

NO.	REVISION	DATE
1	REPLACED MOLDED FILL & VENT , AND PICKUP REPLACED W/ PL3 SERIES	4/28/05
2	ADD Ø2.50" BOSS & GROUND TAG	9/22/05

NOTE: ALL EDGES HAVE R0.375
UNLESS OTHERWISE NOTED

PAGE 1 OF 2

THIS DRAWING AND THE ATTACHED DRAWINGS (AND THE DATA SHOWN THEREON) IS CONFIDENTIAL AND PROPRIETARY AND SHALL NOT BE USED, DISCLOSED TO OTHERS, REPRODUCED FOR ANY PURPOSE EXCEPT FOR QUOTATION TO OR ORDER BY MOELLER MARINE PRODUCTS, INC. AND/OR ITS SUBSIDIARIES WITHOUT THEIR WRITTEN CONSENT TO THE USE OF SUCH DRAWINGS AND/OR DATA.

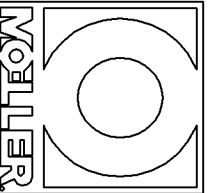

DESCRIPTION	14 GALLON FUEL TANK (032514)		
PART #	FT1499	COLOR	NATURAL
MATERIAL	CROSSLINK POLYETHYLENE		
TOLERANCES	±1.5% UNLESS OTHERWISE NOTED		
WALL THK.	0.200"	DATE	10/24/05
DRAWN BY	MOELLER ENGINEERING		

