

BILL of MATERIALS

| Qty. | DESCRIPTION |
|------|-----------------------------------|
| 1 | PRIME EURO SENDING UNIT 10.85" |
| 1 | ALUM. PL3 PICKUP W/O BARB |
| 4 | HOOK POCKETS W/ OUT BRACKETS |
| 1 | 3/8 NPT INSERT W/ 5/8 BARB (VENT) |
| 1 | Ø1.50 ALUM. FILL W/ GROUND TAG |
| | OVERALL HEIGHT 14.25" |

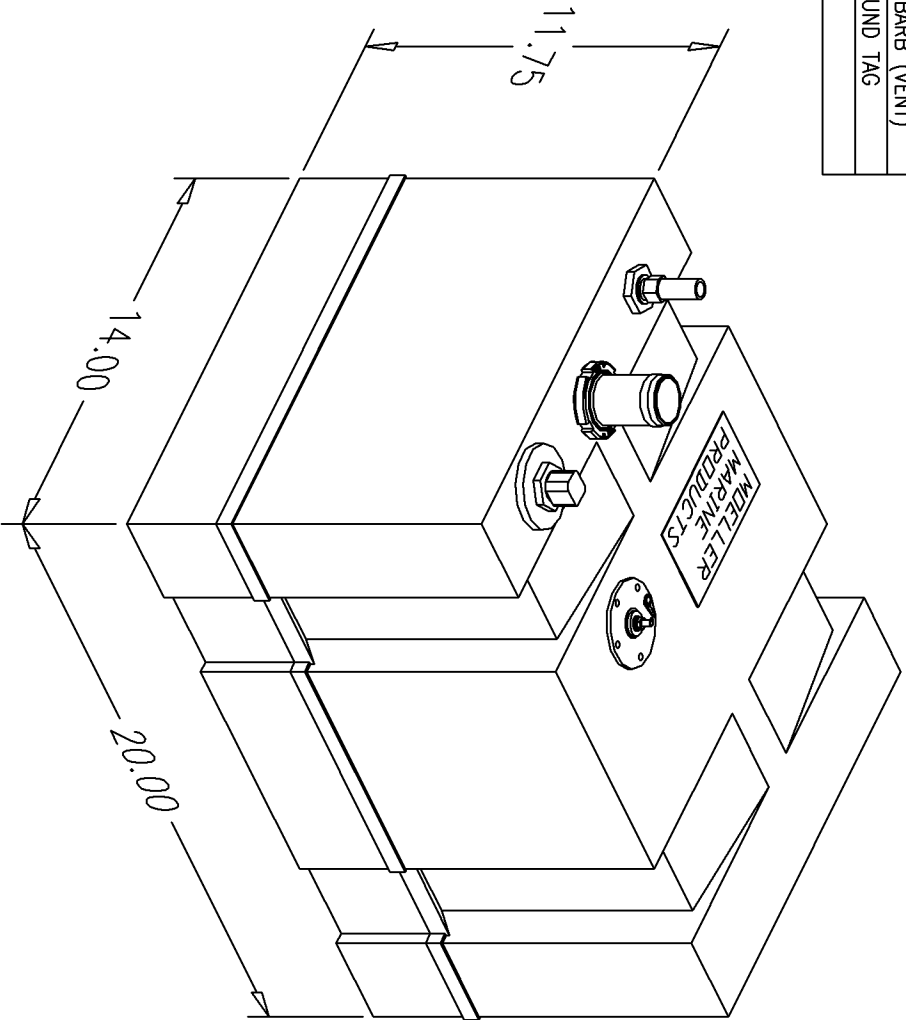

NOTE: ALL EDGES HAVE R0.375
UNLESS OTHERWISE NOTED

PAGE 1 OF 3

THIS DRAWING AND THE ATTACHED DRAWINGS (AND THE DATA SHOWN THEREON) IS CONFIDENTIAL AND PROPRIETARY AND SHALL NOT BE USED, DISCLOSED TO OTHERS, REPRODUCED FOR ANY PURPOSE EXCEPT FOR QUOTATION TO OR ORDER BY MOELLER MARINE PRODUCTS, INC. AND/OR ITS SUBSIDIARIES WITHOUT THEIR WRITTEN CONSENT TO THE USE OF SUCH DRAWINGS AND/OR DATA.

| NO. | REVISION | DATE |
|-----|----------|------|
| | | |

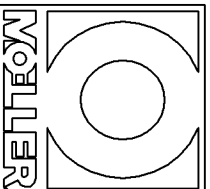
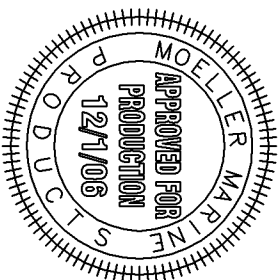

| | |
|-------------|------------------------------|
| DESCRIPTION | 12 GALLON FUEL TANK |
| PART # | FT1294-2 |
| MATERIAL | CROSSLINK POLYETHYLENE |
| TOLERANCES | ±1.5% UNLESS OTHERWISE NOTED |
| WALL THK. | 0.200" |
| DRAWN BY | MOELLER ENGINEERING |
| | COLOR NATURAL |
| | DATE 12/1/06 |